



THE EFFECT OF FILTERED OXYGEN ION IRRADIATION ON REBCO COATED CONDUCTORS

IRRADIATION EFFECTS ON HTS FOR FUSION (IREF25) CONFERENCE
17TH - 22ND JUNE 2025, GALLIPOLI, ITALY

William Iliffe¹
Simon Chislett-McDonald^{1*}
Kirk Adams²
James Tufnall²
Susannah Speller²
Chris Grovenor²
Stuart Wimbush³
Ezzat Nasr³

¹ United Kingdom Atomic Energy Authority (UKAEA), Abingdon, United Kingdom.

² Oxford University Material Department, Oxford, United Kingdom.

³ United Kingdom Industrial Fusion Solutions Ltd (UKIFS), Abingdon, United Kingdom.

(* Now moved on)



WHAT I'M GOING TO TALK ABOUT



1) Introduced the STEP programme.

- UK Public Sector route to commercial Fusion
- STEP Tokamak concept design
- Neutron Loading of the STEP Toroidal Field Coil
- STEP's open questions about REBCO in the Fusion Environment

2) Present Filtered Oxygen Ion Irradiation Experiment

- How we emulated neutrons irradiation with ions
- The experiment design
- & some Results



UK PUBLIC SECTION ROUTE TO COMMERCIAL FUSION



In Operation Goals:

1. To investigate novel exhaust concepts
2. To de-risk / advance the spherical tokamak design, as a future power plant
3. To extend physics knowledge in support of the broader fusion programme

Design Phase

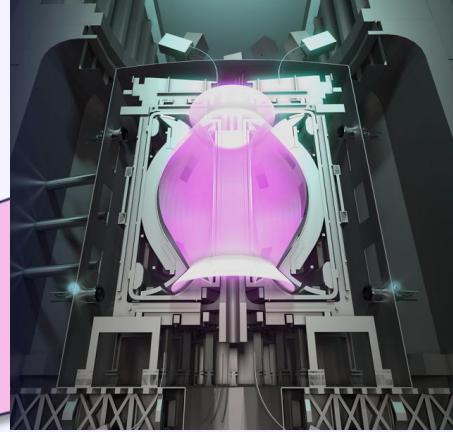

Spherical
Tokamak For
Energy
Productions

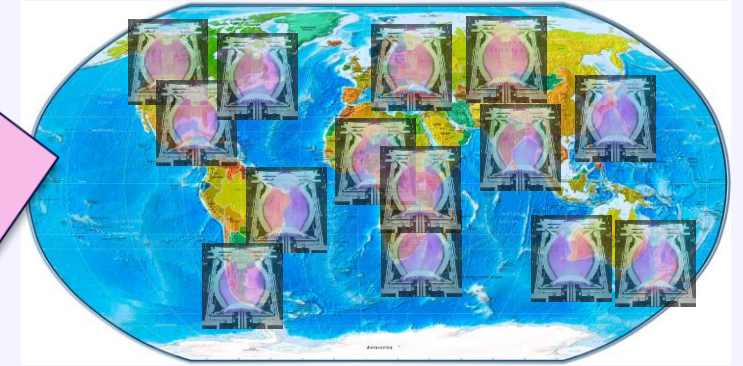

Commercial Fusion

Gainsborough



Main Goals:

- Put electricity of the grid, targeting early 2040s
- Build Supply chain for fusion industry
- Develop UK fusion regulatory framework
- Nurture Skills development

West Burton

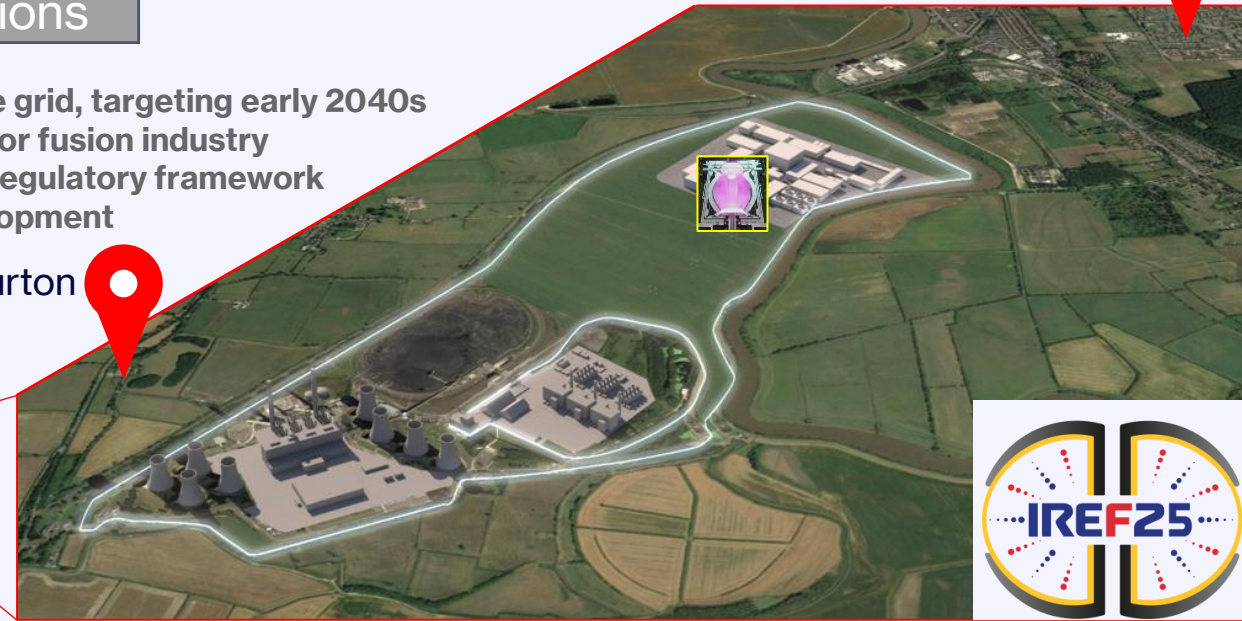

1997: $Q = 0.67$, 16 MW.
2021: 59 MJ over 5 s.
2023: 69 MJ over 5 s.
Now beginning decommissioning.

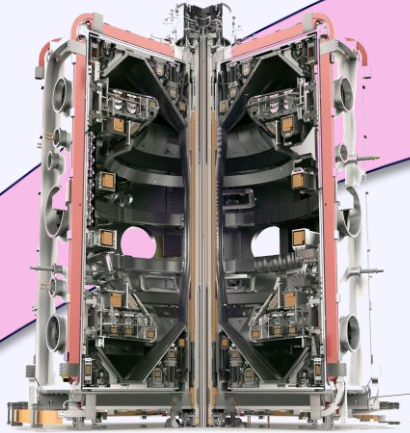

Mega
Amp
Spherical
Tokamak
-Upgrade

Joint
European
Torus

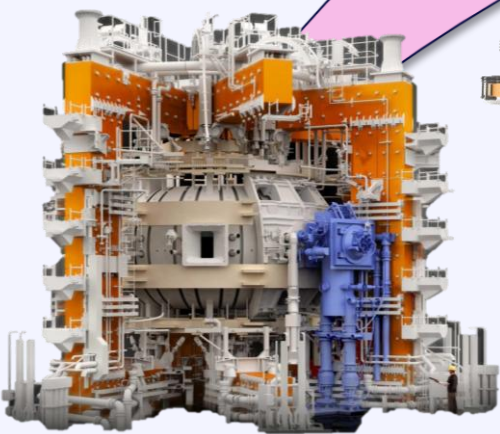

THE STEP TOKAMAK

STEP Special Issue



Q. What is the current STEP design?

A. As described in Special Issue of Phil. Trans. Roy. Soc. A: “Delivering Fusion Energy – The Spherical Tokamak for Energy Production (STEP)”

Major Radius	3.6m
Aspect Ratio	1.8
Elongation	3
Triangularity	+0.5
Magnetic Field (plasma centre)	3.2 T

DT Fusion Power	~1.68 GW
Fusion Power Gain	10.2
Net electric power	~100 MWe
DT Neutron source rate	~ 6×10^{20} n/s

Maintenance Strategy	Vertical with Remountable TF Coils
-----------------------------	------------------------------------

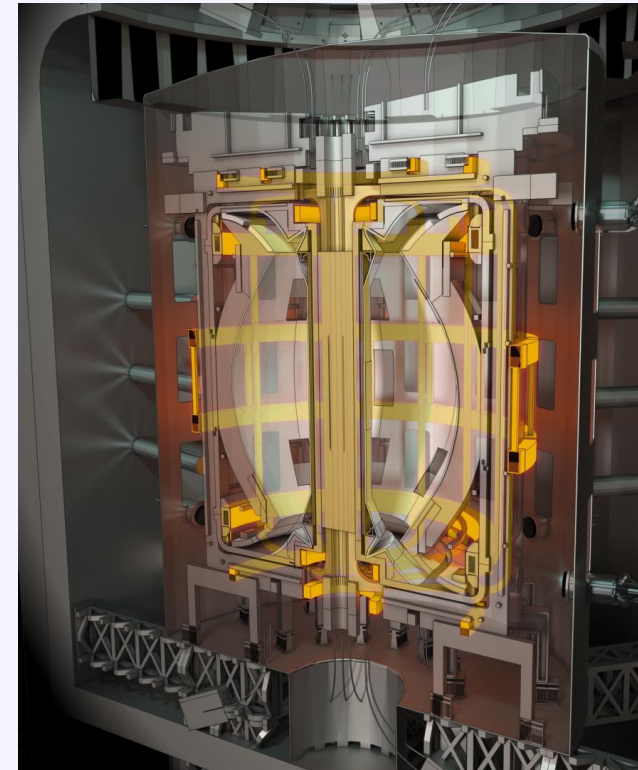

THE STEP TOKAMAK



Q. What level of irradiation do we expect?

Neutron Loading in STEP

$P_{fus} \sim 1680$ MW

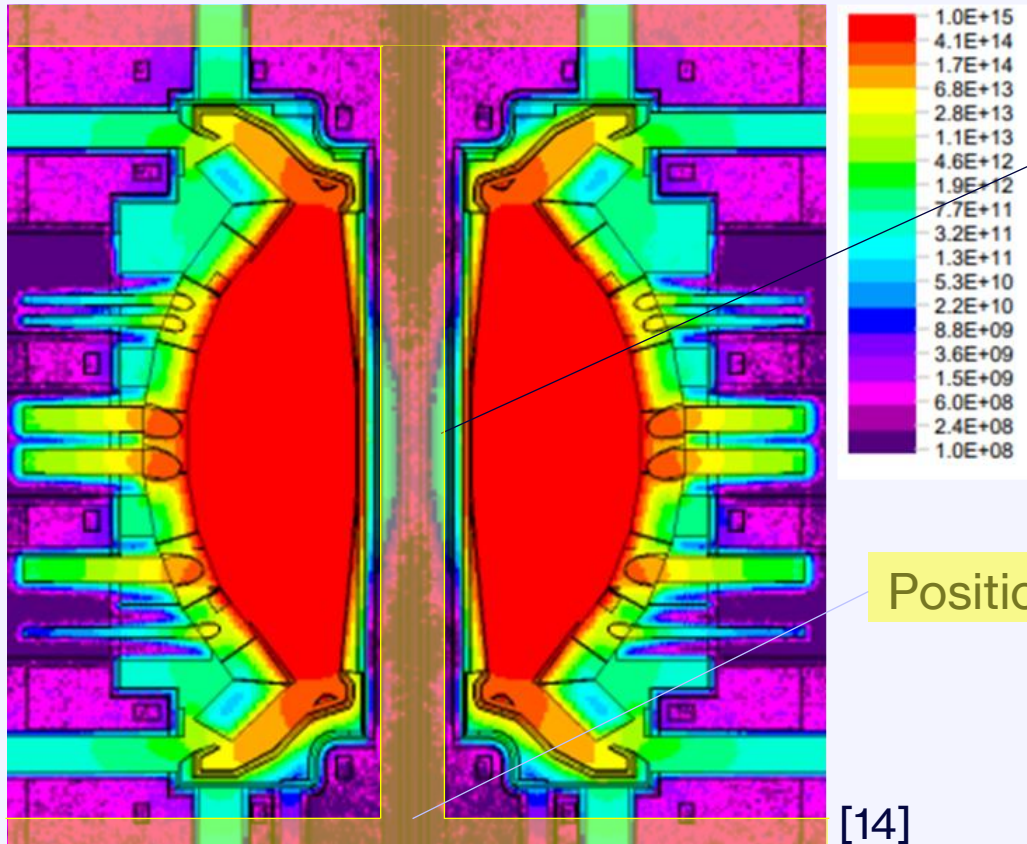

- Inboard region of the TF coils sees $\sim 2 \times 10^{11}$ n/cm²/s neutron fluxes with 8×10^{10} n/cm²/s (40%) with energy > 0.1 MeV.
- At this rate, STEP fast neutron fluence limit for REBCO - 3×10^{18} n_f/cm² - is reached in just ~ 430 days operating at full power (or ~ 1.18 FPY).
- STEP fast neutron fluence limit for REBCO definition: fluence up to which *pre-irradiation properties can be maintained*.



THE STEP TOKAMAK



Open questions about TF lifetime

DT Fusion Power	1.68 GW
DT Neutron source rate	$\sim 6 \times 10^{20}$ n/s
Plasma First Wall Flux	$>10^{15}$ n/cm ² /s
Peak Neutron flux to REBCO in TF	2×10^{11} n/cm ² /s
Peak Fast Neutron flux to REBCO in TF	8×10^{10} n/cm ² /s
Useful Life of TF Centre-rod	1.18 FPY
Peak Fluence to REBCO at end of useful life	3×10^{18} n/cm ²

Paper: STEP's understanding of REBCO in irradiation environment



- Is this lifetime sufficient for STEP to achieve its goals?
Yes but...
- Are we sure? How sure are we?
 - Need more data on more tapes!
- Data implies how tape is made affects its resilience to irradiation...
- How do we test REBCO CC destined for the STEP magnets?
- Does a flux of neutrons influence current carrying capacity of REBCO?

STEP HTS IRRADIATION TEST PLAN



Q. How are STEP addressing these open questions?

A. Perform Experiments!

- In-situ, flux (i.e. irradiation with any source and superconductivity measurements performed **at same time & location**)



- Ex-situ, fluence, proxy (i.e. uses **ions as a proxy** for neutrons for irradiation and superconductivity measurements performed at *different* time/location)

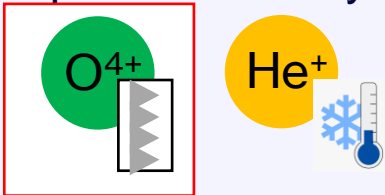

- Ex-situ, fluence, neutrons (i.e. uses **neutrons** for irradiation and superconductivity measurements performed at *different* time/location)



Paper: STEP's progress understanding of REBCO in irradiation environment



The Filter Oxygen Ion Irradiation

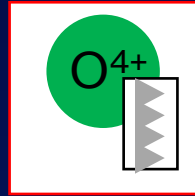

GOALS

Survey response to irradiation of many types of REBCO coated conductor

- Must include tapes from as many suppliers as possible
- Must reach and exceed STEP relevant damage levels
- Should be comparable to literature data

EMULATING NEUTRON IRRADIATION WITH FAST IONS



Simulating Neutron Damage in YBCO – SPECTRA-PKA

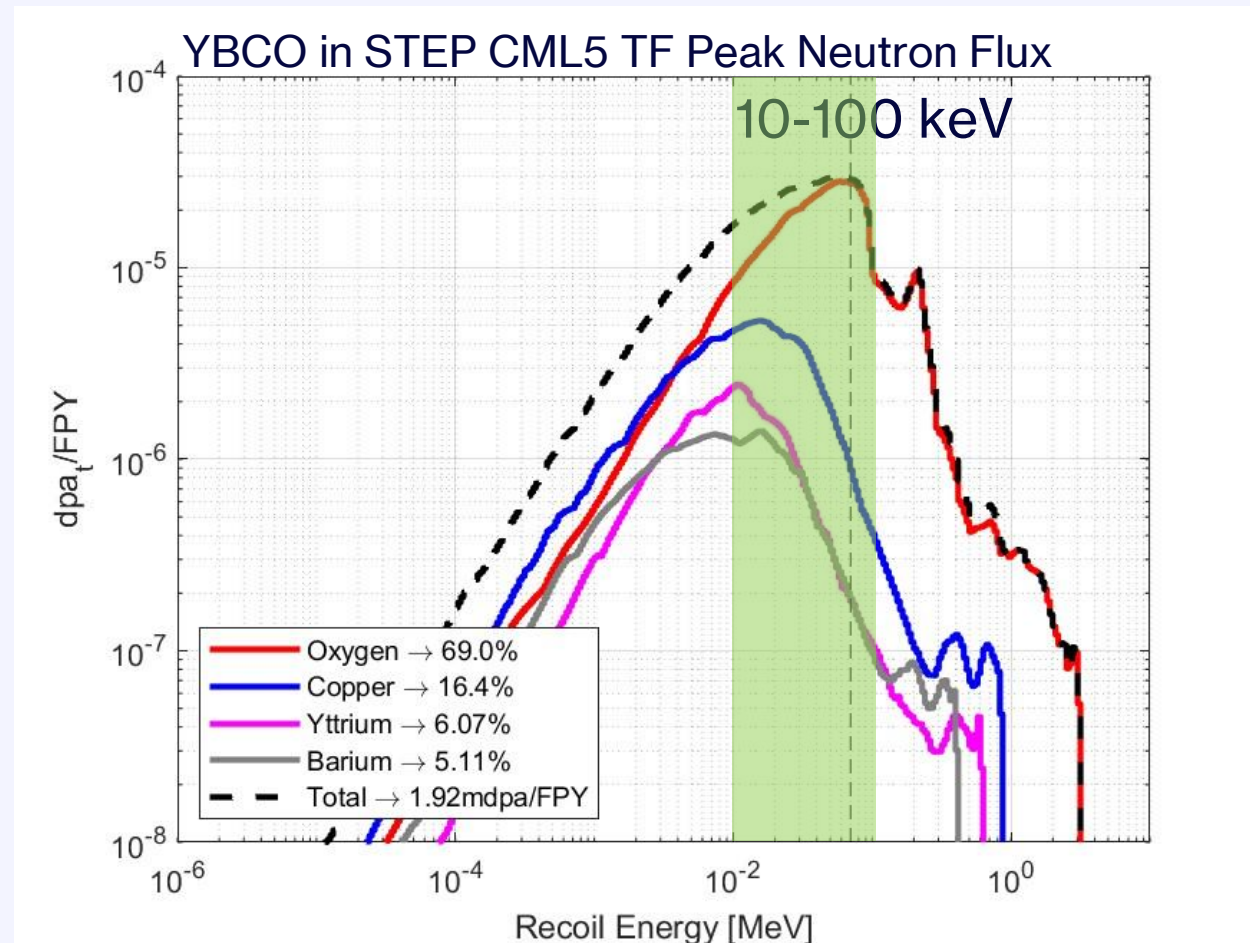

10% of the total damage due to 50-90keV Oxygen PKAs



FAST ION ENERGY FILTER



Q. What are they & what do they do?

[mi2-factory are] "developing and supplying a highly innovative tool for manufacturing efficient power semiconductor microchip"

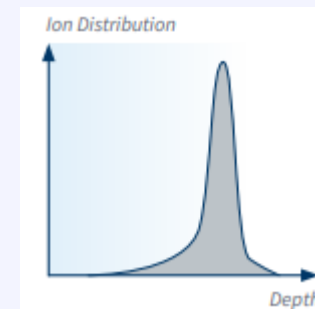

[15]

Filter design as of 2019 (Steinbach et al. [4])

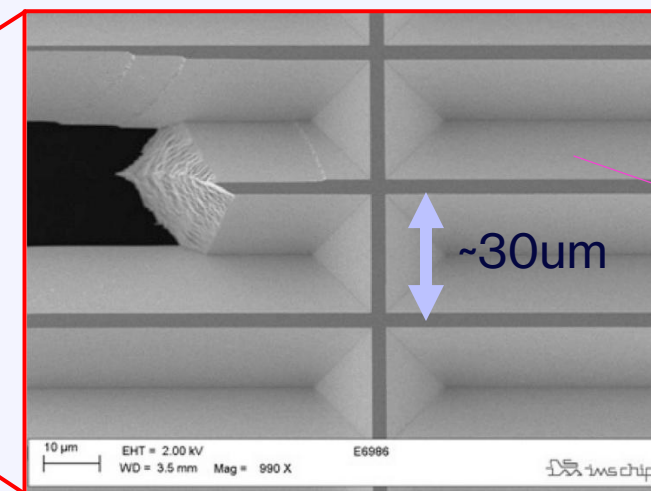
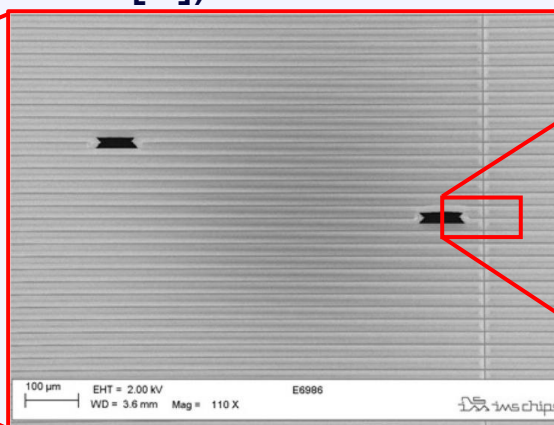
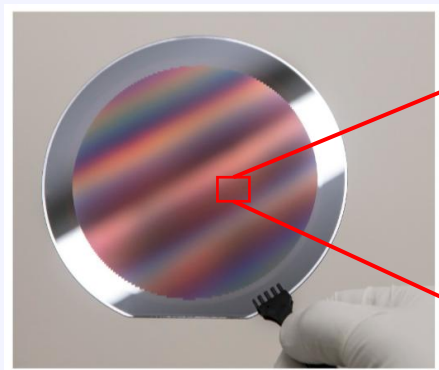

t: ~16μm
t: ~1.5μm

Linear Slope

[4]



FAST ION ENERGY FILTER



Q. But what about the damage profile?

A. We simulated the effect of the filter on ions from a rastering source of 20MeV Oxygen ions

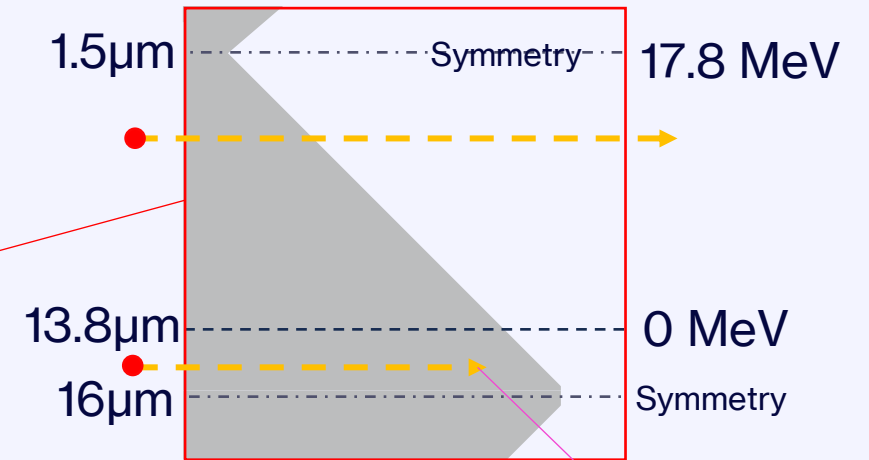
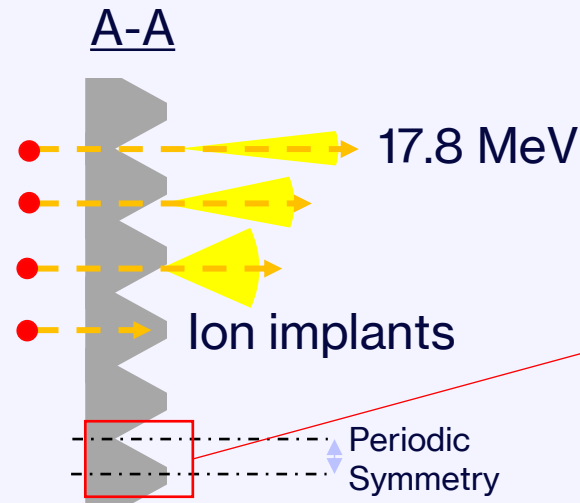
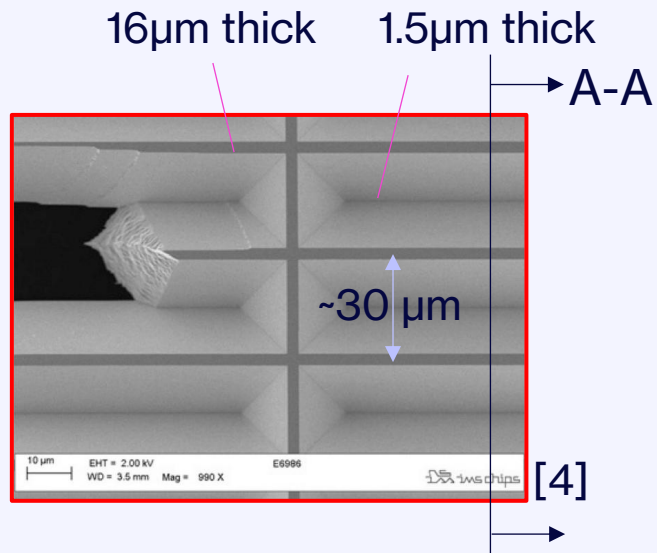

Implanted ions
~30% of total

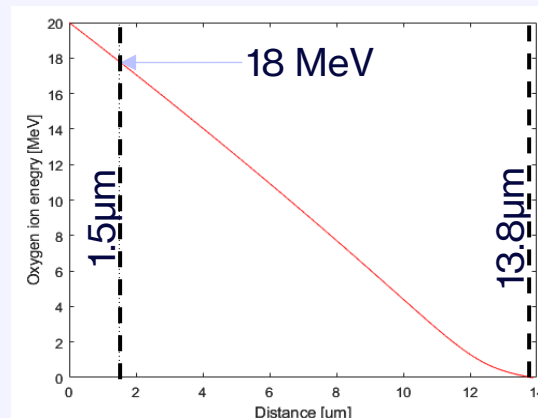

Filter Provided by



FAST ION ENERGY FILTER

Simulating the damage profile cont....

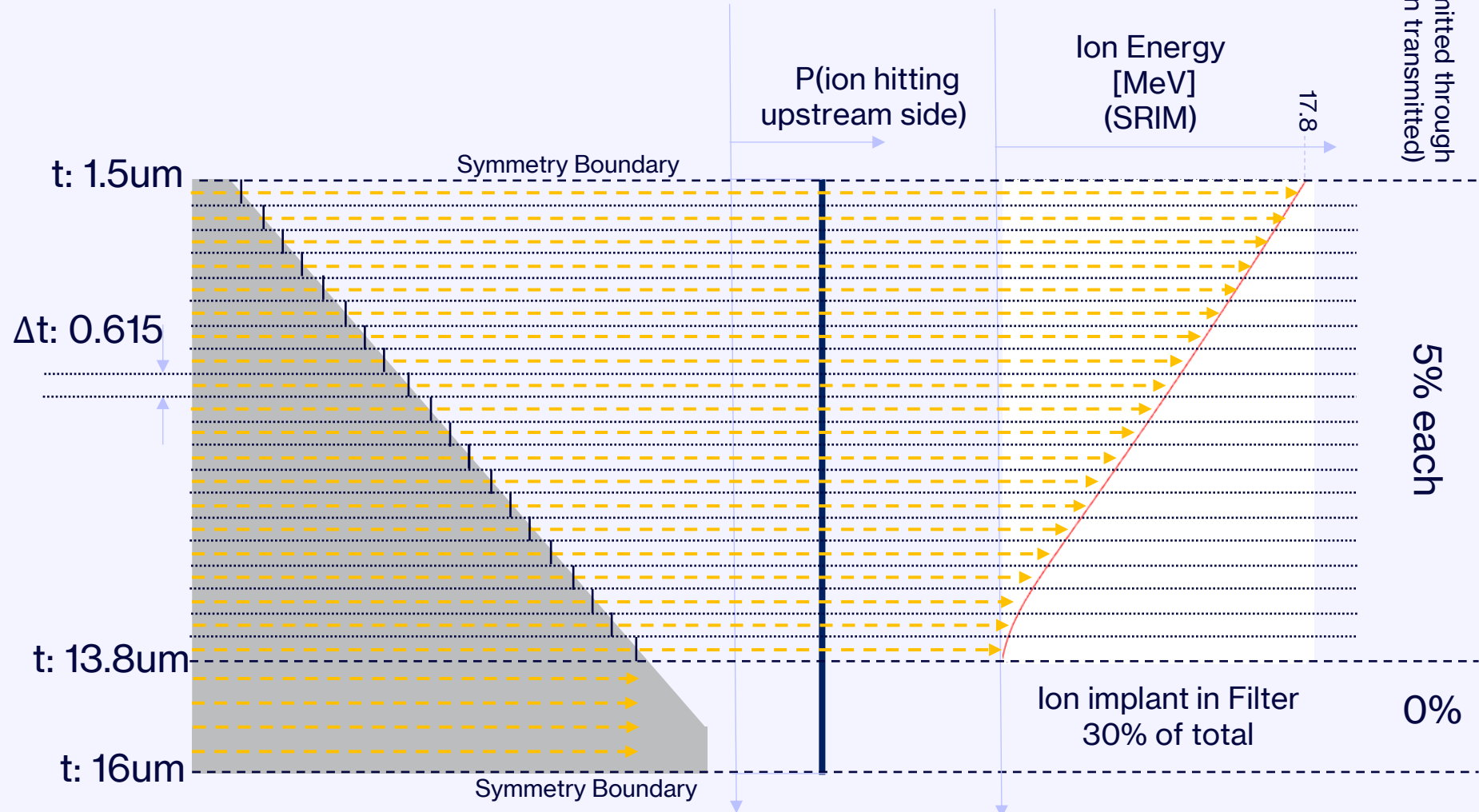

FAST ION ENERGY FILTER



Resulting Damage profile for 20MeV O through a filter

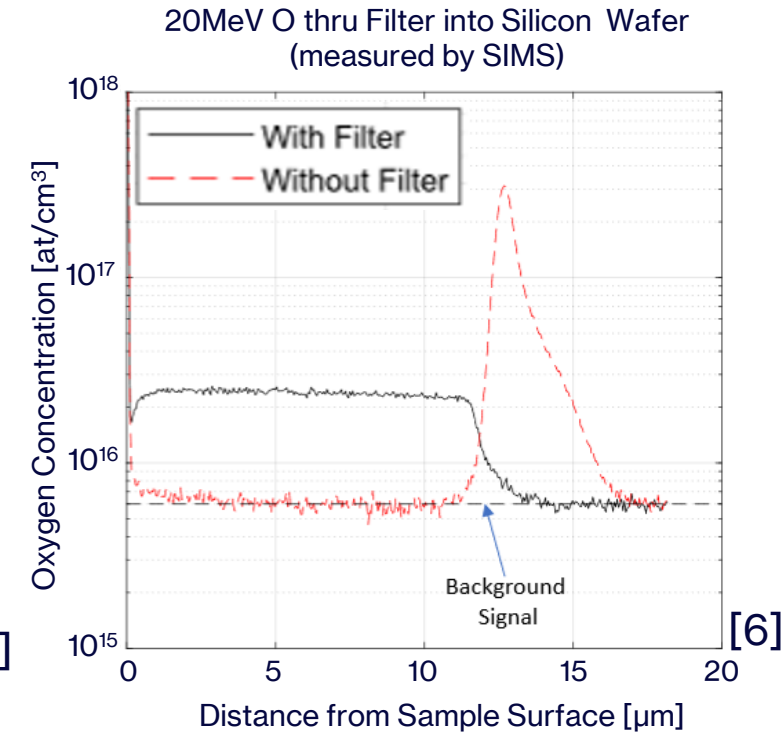
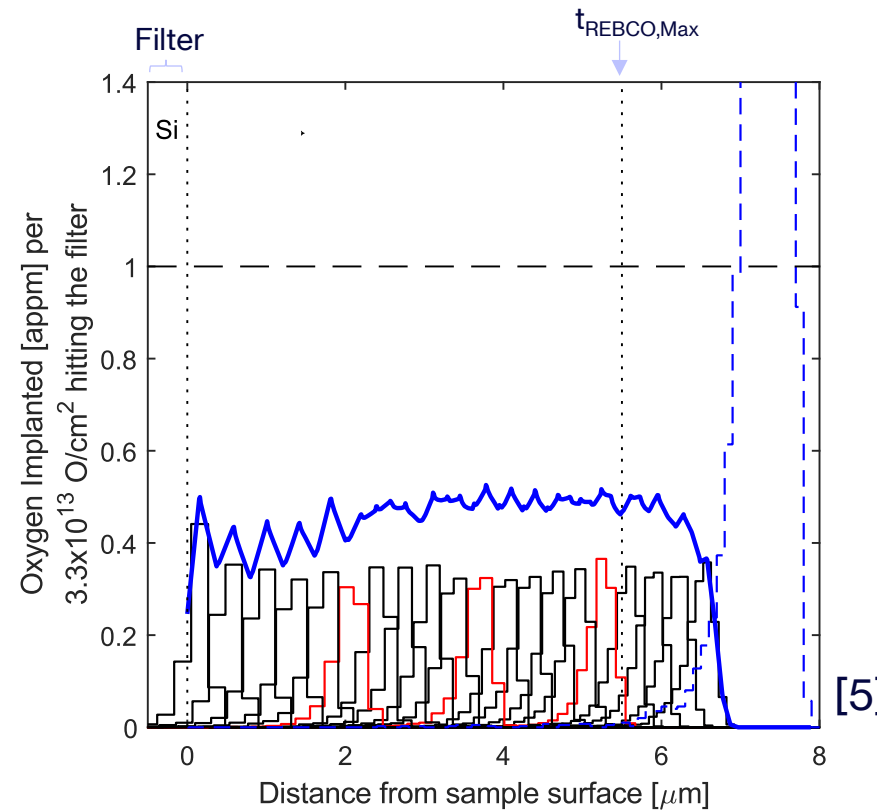
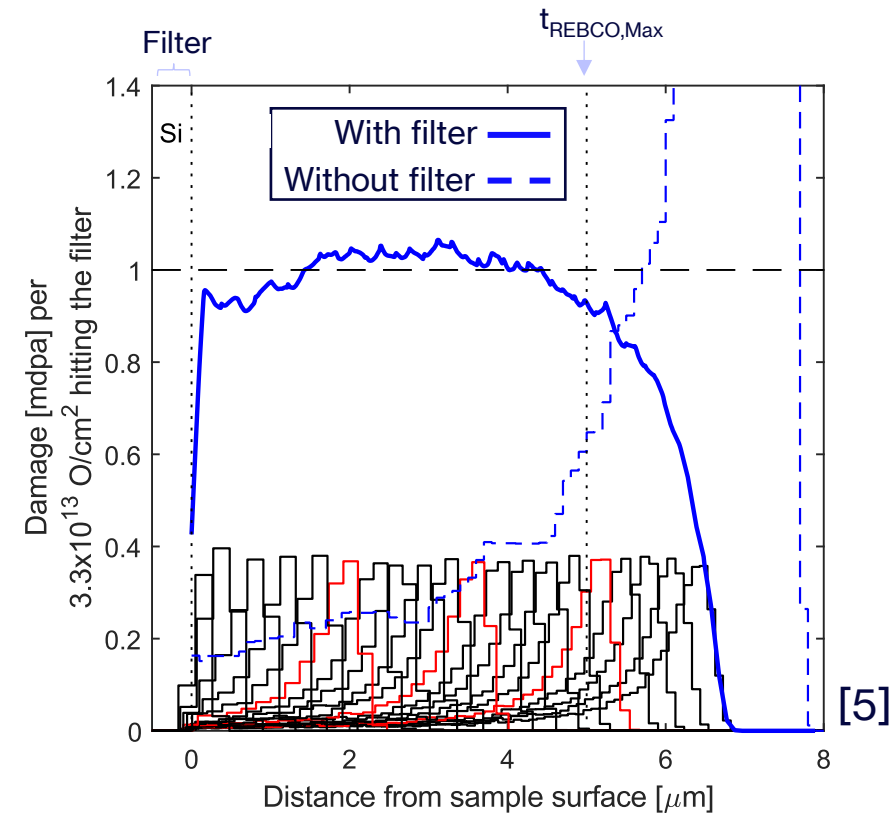

∴ 3.3×10^{13} O/cm² to the filter → 1 ± 0.1 mdpa damage to sample down to ~ 5μm

→ 0.4 ± 0.1 appm oxygen implantation down to ~ 6μm

(compared to 200 appm required to effect T_D)

[Definition: 1 “mdpa” = 1 in every 1000 target atoms has been displaced from its original location by irradiation]



METHODS: IRRADIATION CHARACTERISTICS



Q. What is the experiment set-up?

Reality

Silicon Implantation Experiment (SIMS)

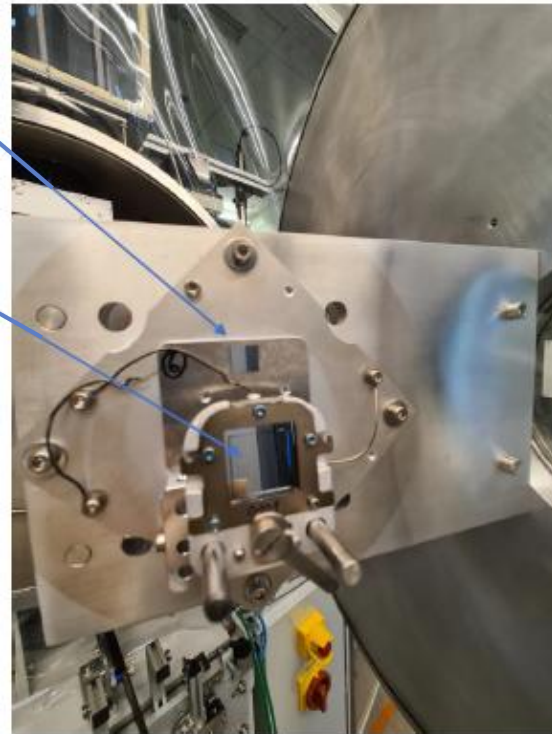

[8]

Mi2-factory : All rights reserved

Sample Plate Assembled behind Filter on Beamline

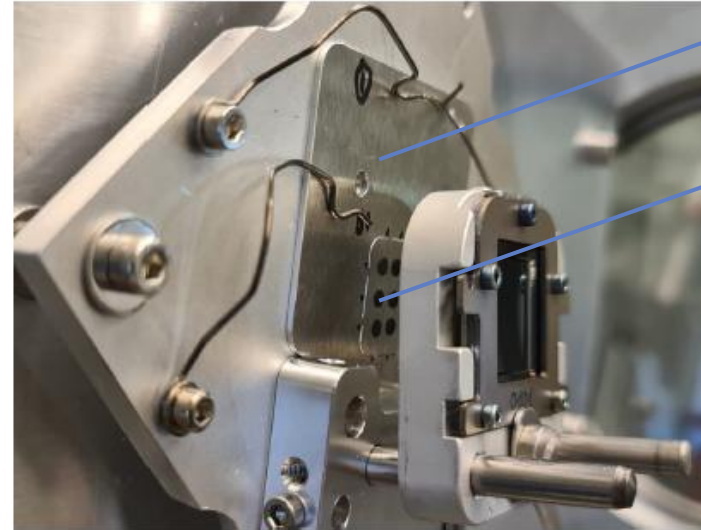

[8]

Mi2-factory : All rights reserved



Aluminium sample plate
REBCO CC Disk Sample



RESULTS



Q. Effect on Critical Temperature at zero field

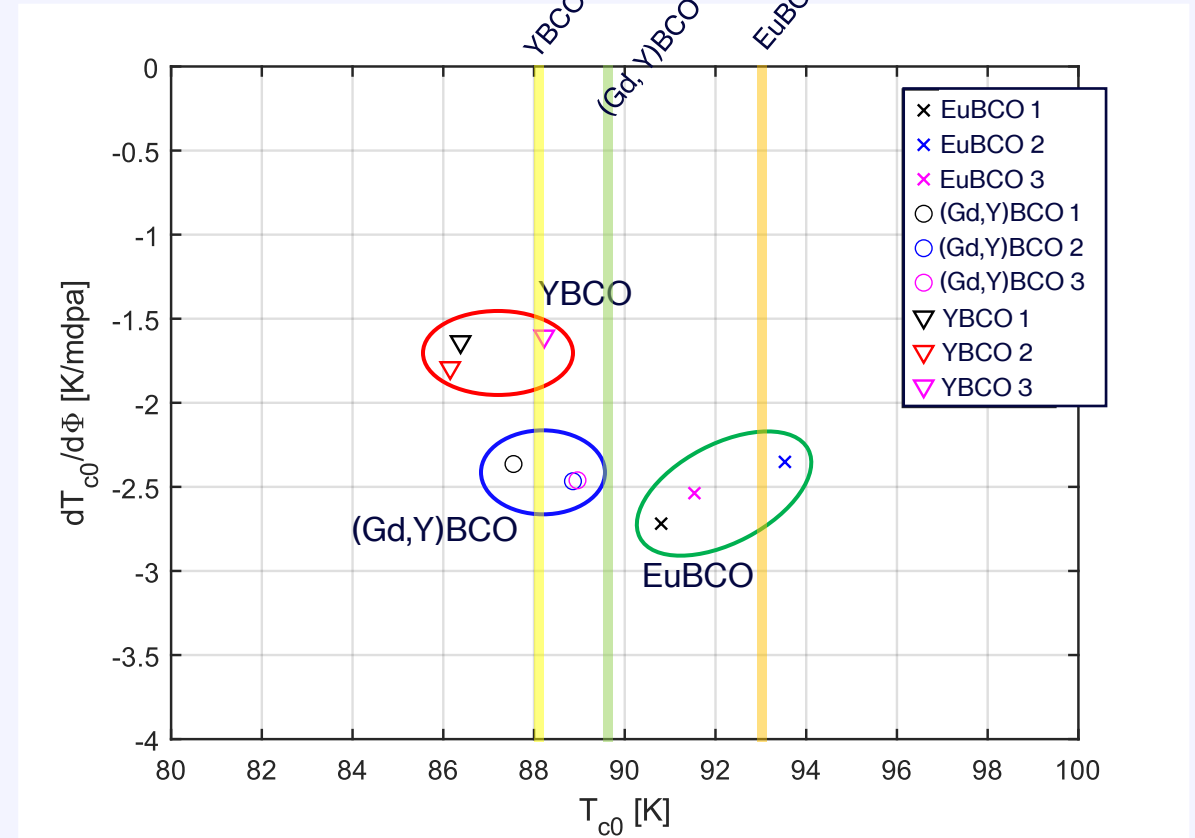
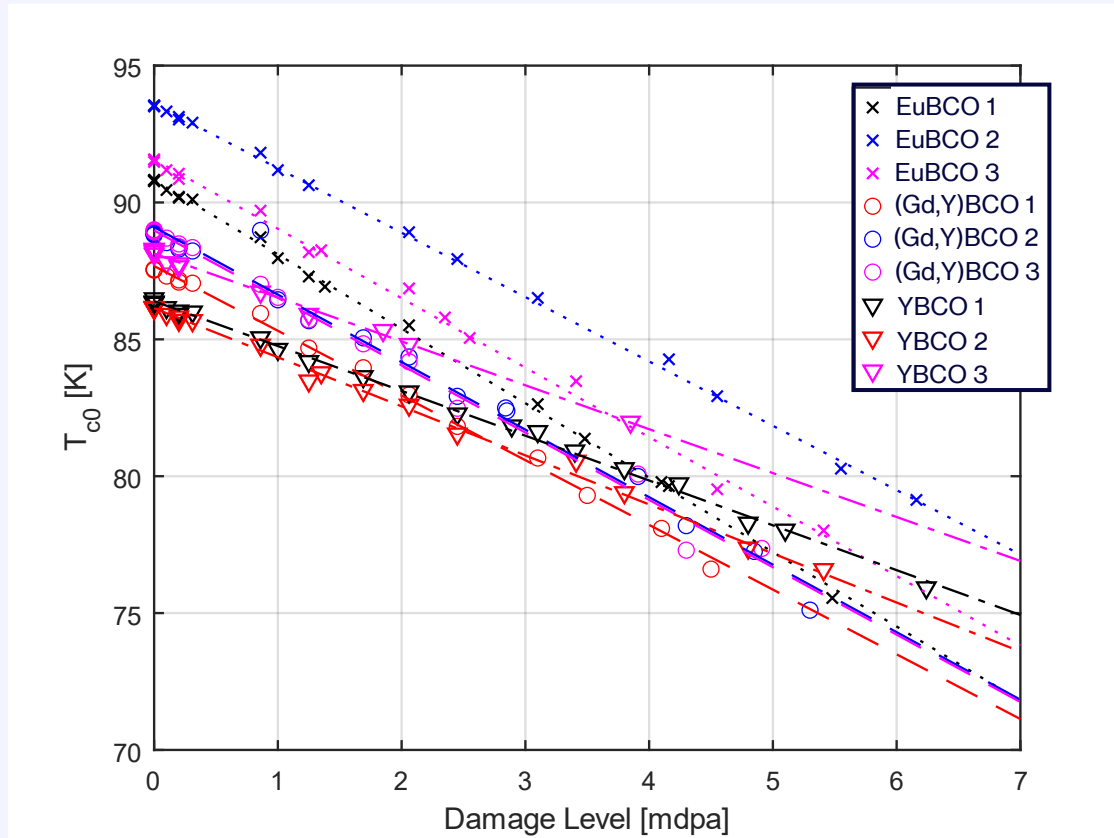

- CC with similar rare earths cluster together, regardless of manufacturer or whether the sample included artificial pinning centres (APCs).



RESULTS



Q. Effect on Critical Temperature at zero field

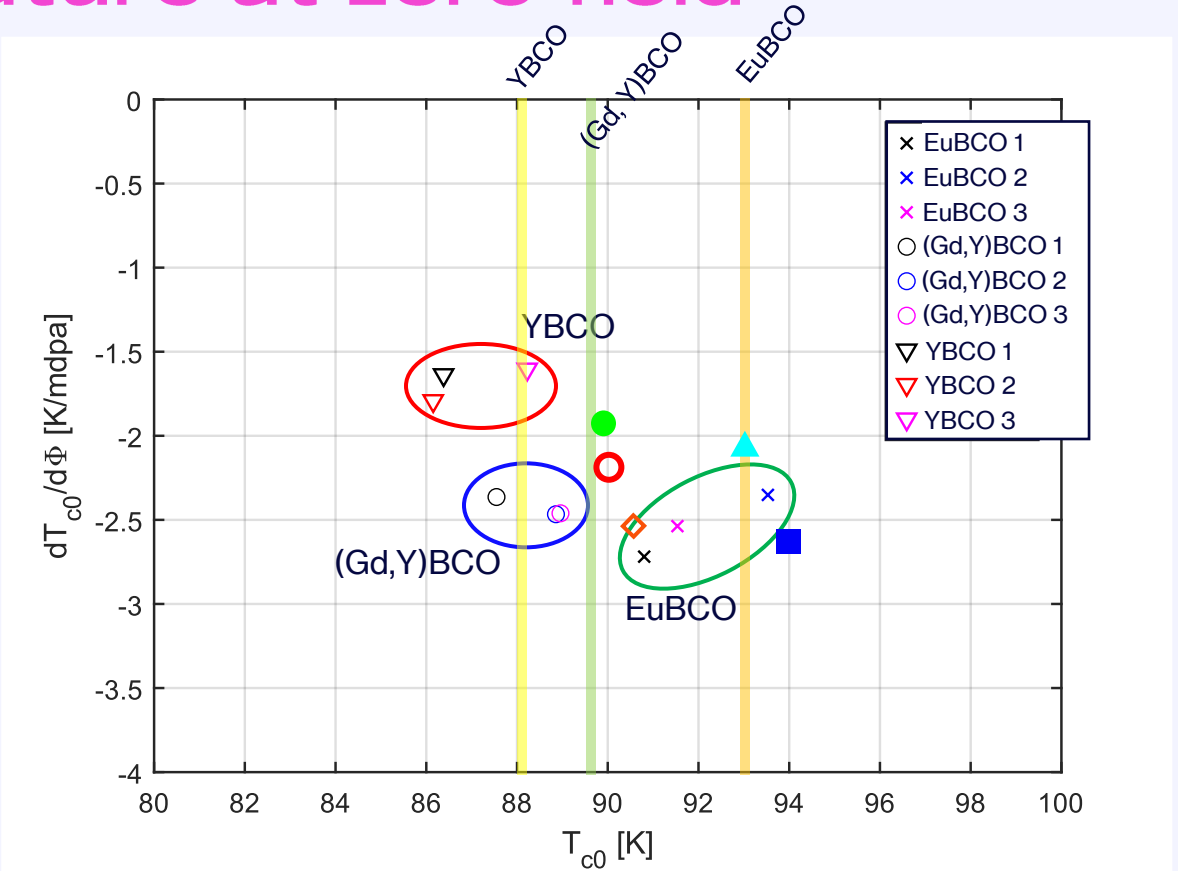
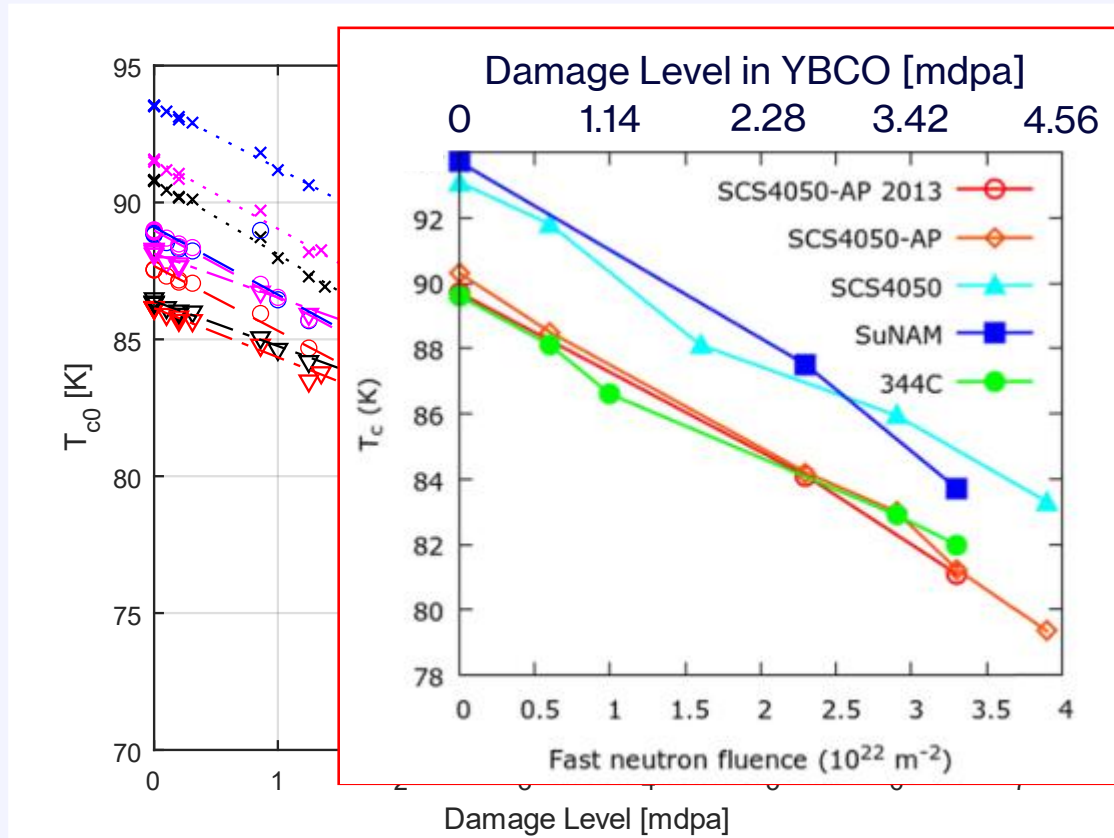

- CC with similar rare earths cluster together, regardless of manufacturer or whether the sample included artificial pinning centres (APCs).
- Comparison to results of neutron irradiation experiment shows results in similar damage rates though not T_c , perhaps due to different measurement methods.



RESULTS



Q. Effect on $I_{cpw}(B, T)$?

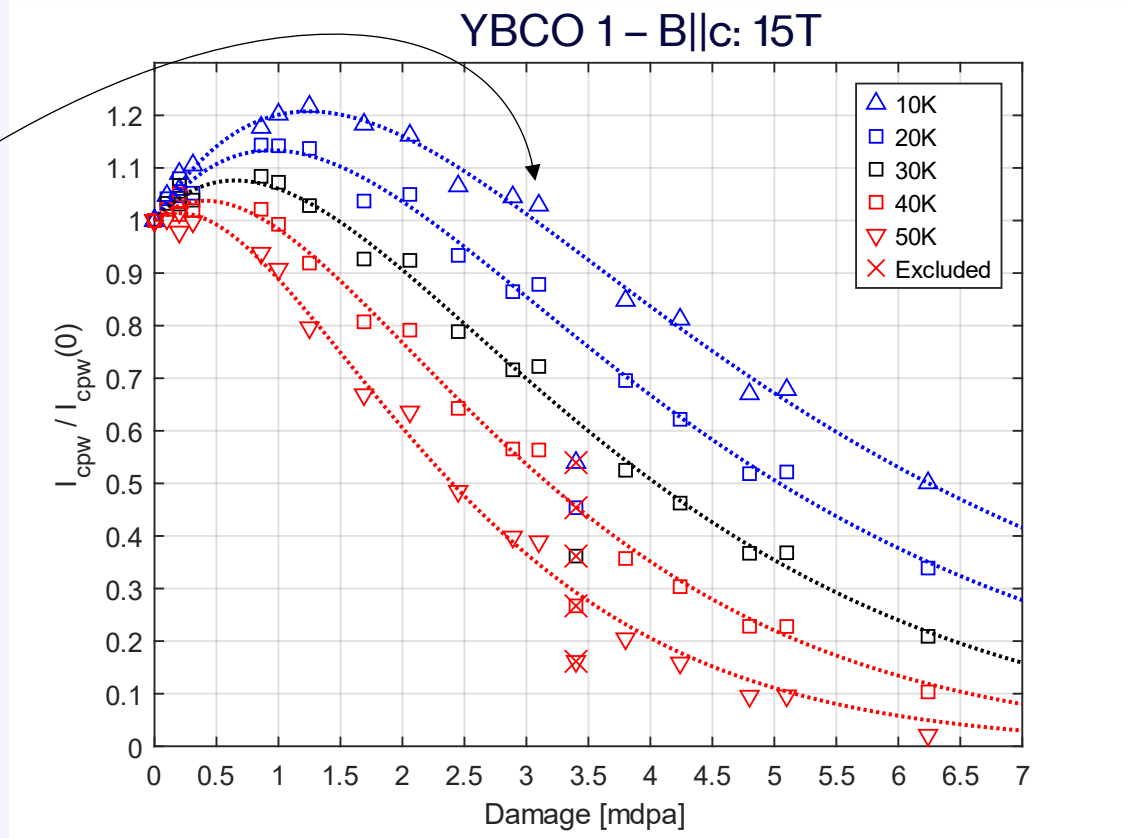
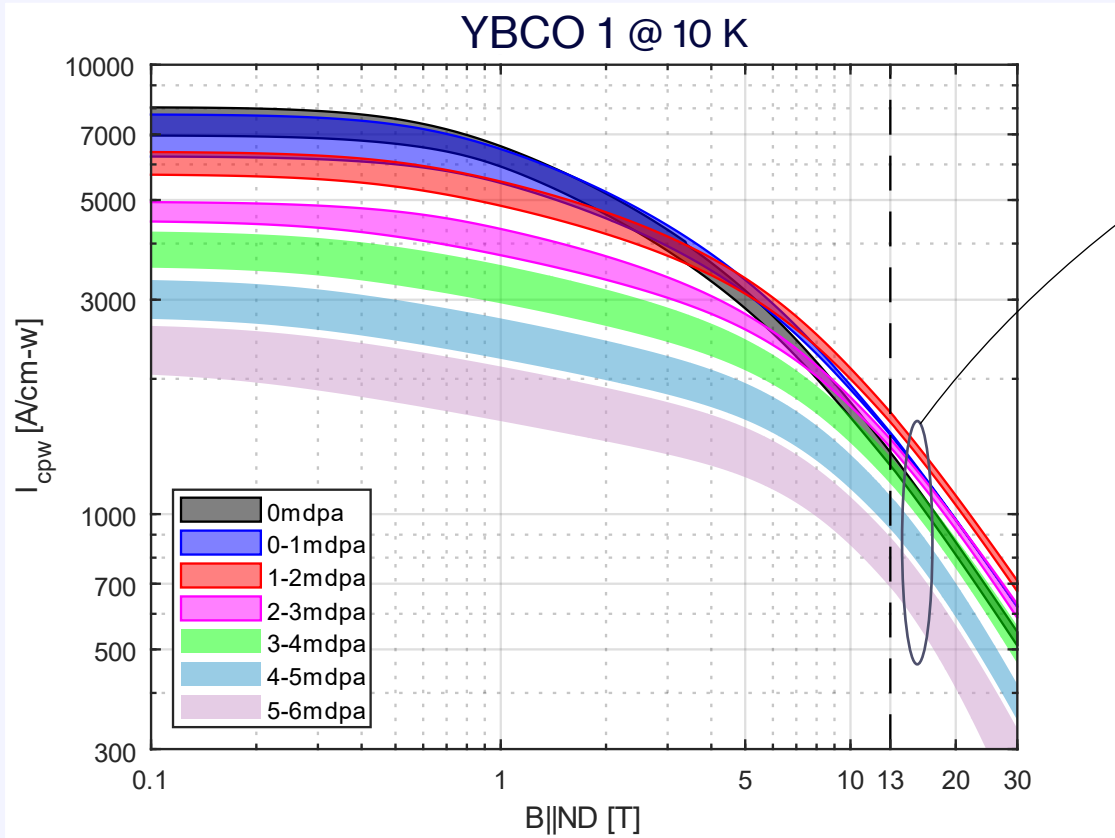

- Decreasing temperature \rightarrow better irradiation resistance.
- Trajectory of change in I_{cpw} fit well with combination of flux pinning enhancement (from [9]) and exponential decay, characteristic of a loss in superconducting volume.

$$\frac{I_{cpw}}{I_{cpw}(0)} = \underbrace{D_{enh} \tanh\left(\frac{D+D_0}{D_n}\right)}_{\text{Pinning Efficiency}} \underbrace{\exp\{-\lambda D\}}_{\text{Superconducting Volume Loss}}$$



RESULTS



Q. Effects on $I_{cpw}(B, T)$ – Comparing Samples Types

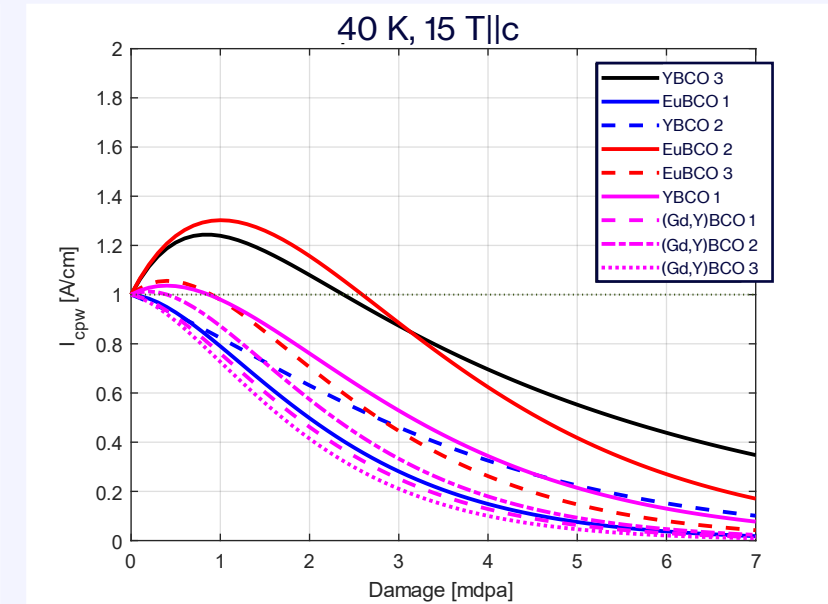
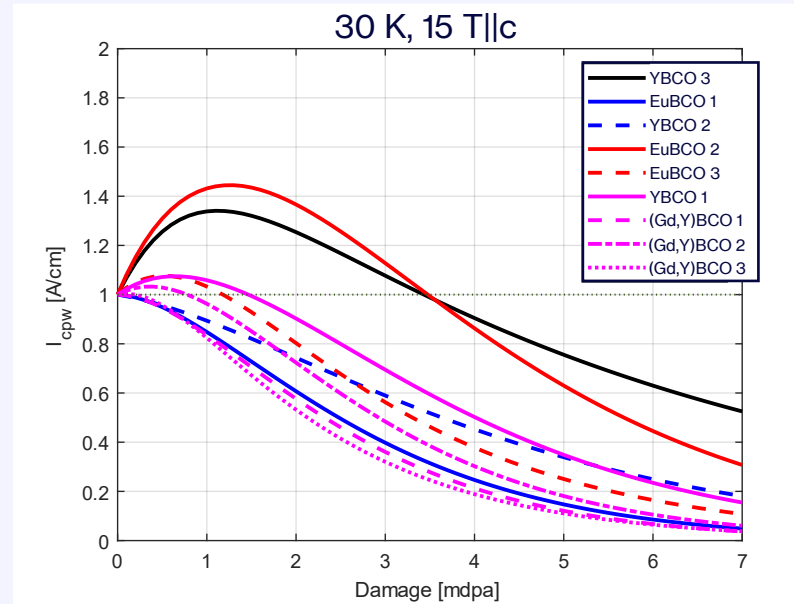
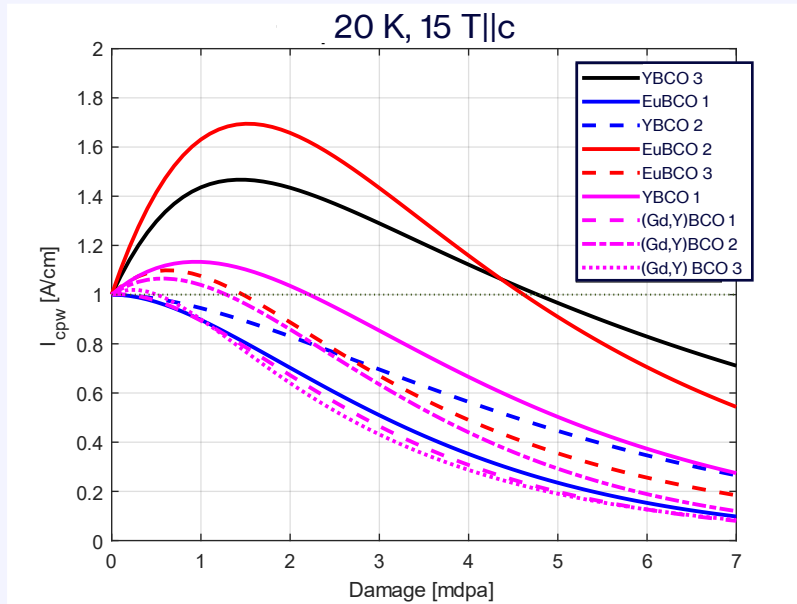

Next, we compare the relative change in I_{cpw} between samples of different types.

As suggested by literature, sample types with **no artificial pinning** show **most improvement** in I_{cpw} upon irradiation.

Some samples show **zero improvement** in I_{cpw} with irradiation, suggesting **artificial pinning** has **over saturated** REBCO layer with defects.

When comparing to neutron irradiation results, point where initial I_{cpw} reestablished for non-pinned samples is comparable.



RESULTS



Q. Effects on $I_{cpw}(B, T)$ – Comparing Samples Types

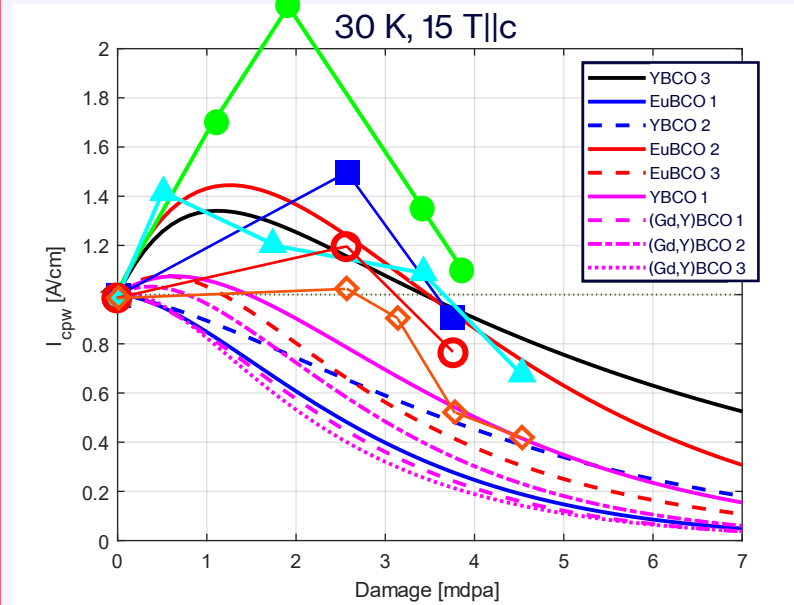
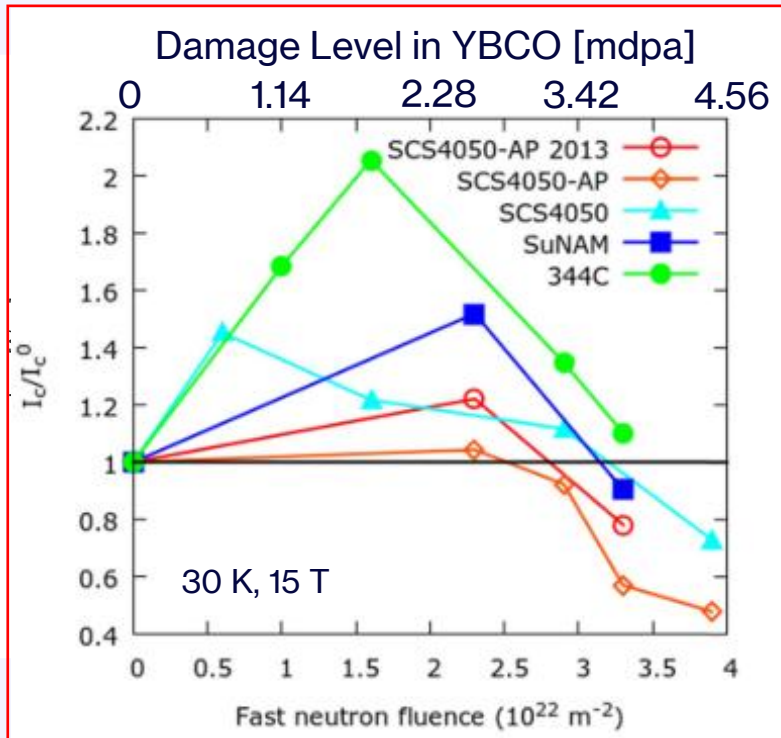

Some samples show **zero improvement** in I_{cpw} with irradiation, suggesting **artificial pinning** has **oversaturated** REBCO layer with defects.

When comparing to neutron irradiation results, point where initial I_{cpw} reestablished for non-pinned samples is comparable.

Next, we compare the relative change in I_{cpw} between samples of different types.

As suggested by literature, sample types with **no artificial pinning** show **most improvement** in I_{cpw} upon irradiation.



RESULTS



Q. Effects on $I_{cpw}(B, T)$ – Comparing Samples Types

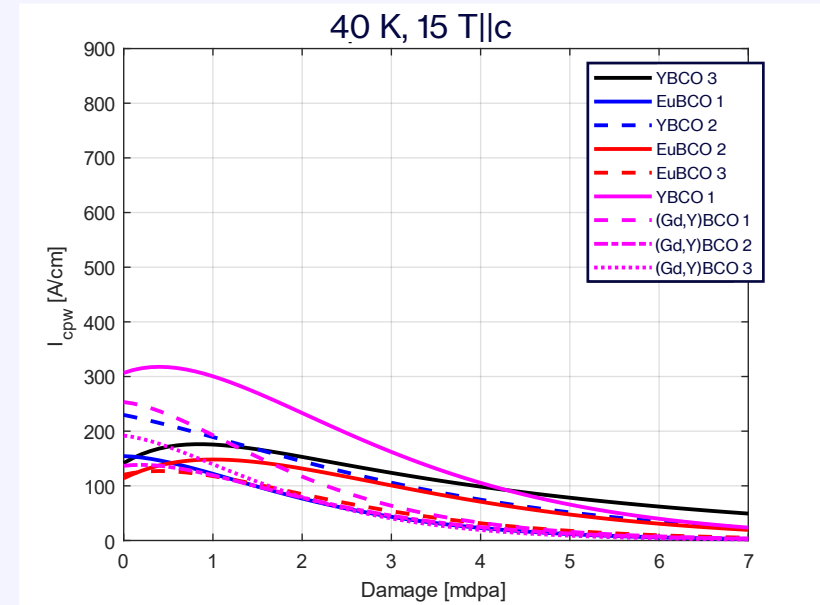
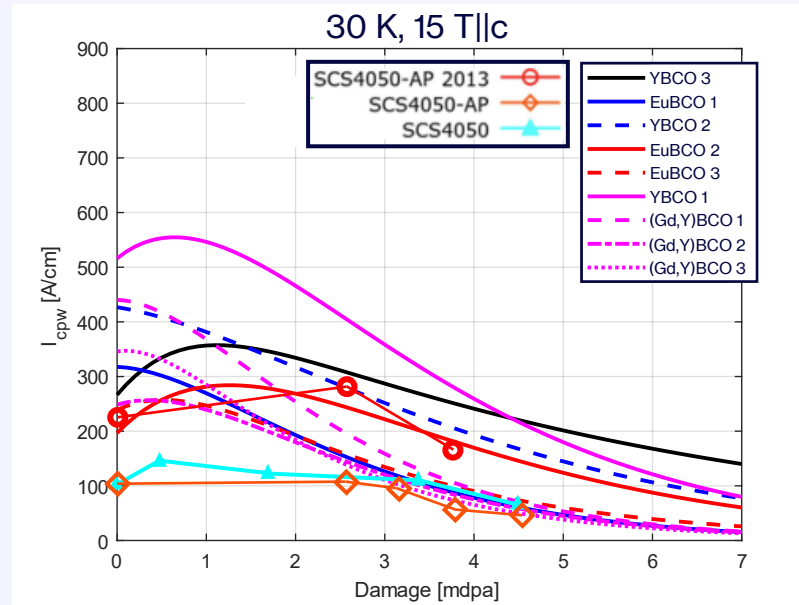
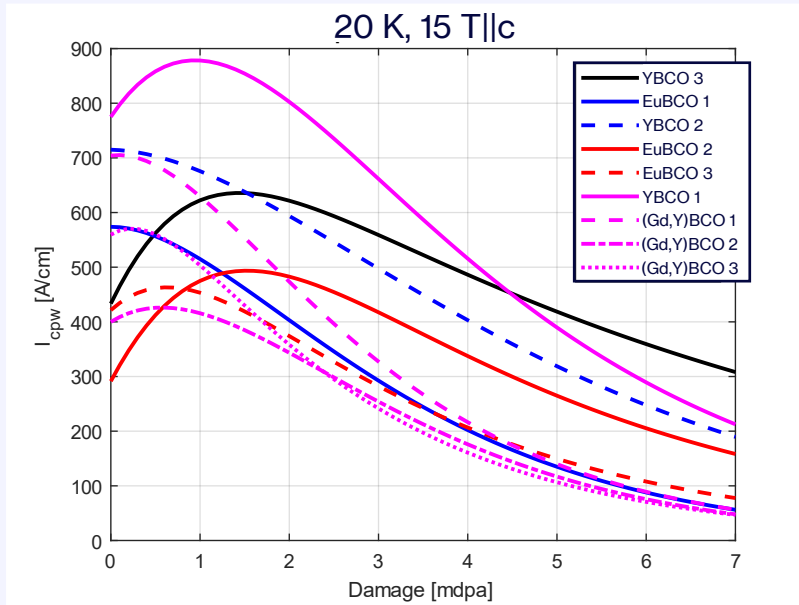

Relative changes are great... but, for fusion applications, absolute current carrying capacity is key...

Shown are the fits of high field I_{cpw} for all sample type, **scaled by sample averaged initial values.**

Results show that Temperature control, not only effects magnet performance, **but also effects magnet lifetime!**

Un-artificially pinned tapes have **slower exponential decay** than pinned tapes.

Many tapes **converge to similar critical current levels** at 3-4mdpa. Suggests pinning now dominated by defects created by irradiation.



SUMMARY & CONCLUSIONS



In this work:

- Introduced the STEP programme.
- Several commercially available coated conductors were oxygen ion irradiated through an energy filter in steps up to and beyond the damage level expected in STEP.
- The irradiation used an energy filter to more closely mimic irradiation with fusion spectrum neutrons.

Conclusions:

- Compared to using monoenergetic ions, using an **energy filter** results in:
 - More uniform volume homogeneity of irradiation damage and bombarding ion implantation.
 - 1/3 fluence needed to achieve same damage level.
 - Larger fraction of total collisions ion-to-target nuclei.
- Choice of **rare-earth in REBCO** affects both the starting critical temperature and the rate of its monotonic decline with damage level.
- $\frac{I_{cpw}(D)}{I_{cpw}(0)}$ trajectory affected by temperature, field strength and defect density in REBCO.
- That $\frac{I_{cpw}(D)}{I_{cpw}(0)}$ can be modelled as a combination of **changing pinning efficiency** and a **loss in superconducting volume**.
- Some CC over-saturated with defect, leading to no improvement in I_{cpw} upon irradiation.
- Un-artificially pinned samples show slower exponential decay in I_{cpw} after their pinning efficiency has saturated.
- Many tapes converge to similar I_{cpw} at 3 - 4mdpa, suggesting pinning now **dominated by defects created by irradiation**.



ACKNOWLEDGEMENTS



This work has been funded by **STEP**, a major technology and infrastructure programme led by UK Industrial Fusion Solutions Ltd (**UKIFS**), which aims to deliver the UK's prototype fusion powerplant and a path to the commercial viability of fusion.

This work was supported by the Ion Beam Centre at **HZDR**, Dresden, Germany and **mi2-factory** based in Jena, Germany.

The research used UKAEA's **Materials Research Facility**, which has been funded by and is part of the UK's National Nuclear User Facility and Henry Royce Institute for Advanced Materials.

Thanks go to:

- @ HZDR & mi2 Factory
- Constantin Csato
 - Shavkat Akhmadaliev
 - Florian Krippendorf
 - Stefan Illhardt
 - Beam operators at HZDR





COPYRIGHT NOTICE

This original presentation was created by
William Iliffe, HTS Irradiation Test Plan Lead,
on 3/07/2025.

Copyright © UK Industrial Fusion Solutions Ltd. 2024. All rights reserved.

No part of this publication may be reproduced, stored in a retrieval system of any nature, or transmitted, in any form or by any means including photocopying and recording, without the prior written permission of the copyright owner.

Licences issued by the Copyright Licensing Agency or any other reproduction rights organisation do not apply. If any unauthorised acts are carried out in relation to this copyright work, a civil claim for damages may be made and/or a criminal prosecution may result.